

*Applied Pumps - The Experts in Hot Cooking Oil Applications*

---

# E & G Series Pumps

Since 1972, Haight Pump has earned a well deserved reputation for our expertise in this highly competitive market. With over thirty years experience supplying equipment that meets the design and performance criteria for an astounding variety of customers, we can help you meet your performance goals. Haight's versatility, durable construction, and competitive price has proven a winning combination in hundreds of thousands of commercial kitchens, stores and factories throughout the world.

## *Offering:*

- A proven selection of different internal gear designs, each optimized for specific operating characteristics, all NSF approved
- Multiple flow rates to match your application capacity
- Motor variations with UL, CSA, or CE approval to meet application specifications.
- We excel in adapting our product to meet your special design challenges.
- Our Product Warranty is the best in the industry.



**5E Series Pump**



**8G Series Pump**



Hub Mount

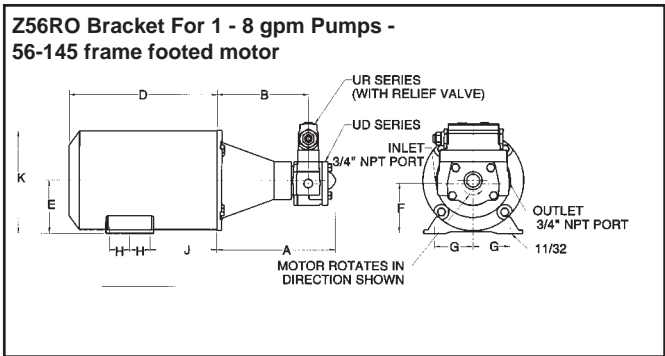

| Model | A                               | B                               | D                             | E                             | F                               | G                              | H                             | J                              | K                               |
|-------|---------------------------------|---------------------------------|-------------------------------|-------------------------------|---------------------------------|--------------------------------|-------------------------------|--------------------------------|---------------------------------|
| 1E    | 7 <sup>13</sup> / <sub>16</sub> | 5 <sup>15</sup> / <sub>16</sub> |                               |                               |                                 |                                |                               |                                |                                 |
| 3E    | 7 <sup>13</sup> / <sub>16</sub> | 5 <sup>15</sup> / <sub>16</sub> |                               |                               |                                 |                                |                               |                                |                                 |
| 5E    | 8                               | 5 <sup>15</sup> / <sub>16</sub> |                               |                               |                                 |                                |                               |                                |                                 |
| 6G    | 8 <sup>5</sup> / <sub>16</sub>  | 5 <sup>15</sup> / <sub>16</sub> |                               |                               |                                 |                                |                               |                                |                                 |
| 8G    | 8 <sup>7</sup> / <sub>16</sub>  | 5 <sup>15</sup> / <sub>16</sub> |                               |                               |                                 |                                |                               |                                |                                 |
| Frame | 48                              |                                 | 9 <sup>3</sup> / <sub>8</sub> | 3                             | 2 <sup>13</sup> / <sub>16</sub> | 2 <sup>1</sup> / <sub>8</sub>  | 1 <sup>3</sup> / <sub>8</sub> | 2 <sup>5</sup> / <sub>16</sub> | 5 <sup>13</sup> / <sub>16</sub> |
| 56    |                                 |                                 | 9 <sup>3</sup> / <sub>4</sub> | 3 <sup>1</sup> / <sub>2</sub> | 3 <sup>5</sup> / <sub>16</sub>  | 2 <sup>7</sup> / <sub>16</sub> | 1 <sup>1</sup> / <sub>2</sub> | 2 <sup>9</sup> / <sub>16</sub> | 6 <sup>3</sup> / <sub>4</sub>   |

"D" Dimension will vary with motor enclosure

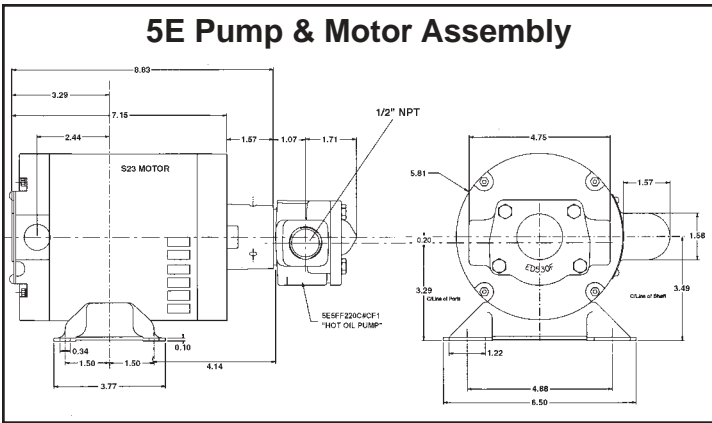

Pump with Motor

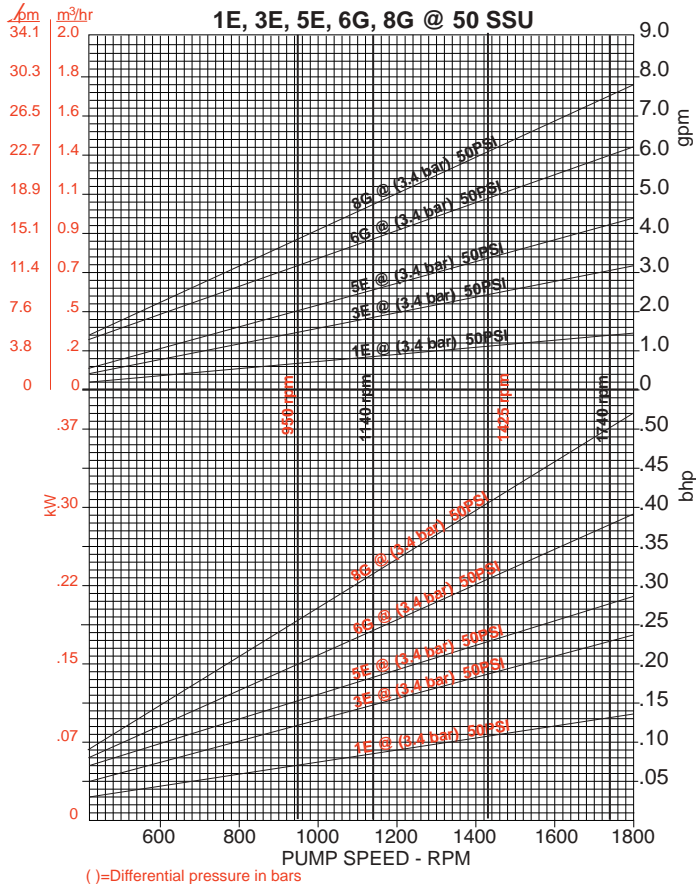

Additional Pump sizes available up to 80 GPM

Using the right Haight Pump can save you money in efficiency and down time. Haight Pump offers a complete line of hot cooking oil pumping solutions with versatile, compact, and adaptable size options, with durable construction, at competitive prices.

Recognized in the hot cooking oil industry as the leader in every aspect of hot cooking oil pump application, design, sales, and service, Haight pumps are found in, and serve entire industries including:

- Fast Food, Casual, Elite, and Family Restaurants
- Bakeries
- Donut Makers
- Snack Food Producers

**Contact**

For information on any of our pumps, call or write:  
 Applied Pumps Ltd  
 11 Cobnar Wood Close, Chesterfield, S419RQ  
 Phone: 01246 260102 • Fax: 01246 260103  
 Website: [www.gearpumpsuk.co.uk](http://www.gearpumpsuk.co.uk)